

 SP. A.

WARRANTY
WARRANTY
WARRANTY
3
YEARS
WARRANTY
WARRANTY
WARRANTY

NEW
**RENAULT
TRIBER**



available with CNG



SALES &
SERVICE

SALES

Cuddalore | Villupuram | Kallakurichi
Chidambaram | Neyveli | Virudhachalam



88 99 110 110

We are open on Sundays

rethink space

Stylish allure highlighted by the new Renault identity and best-in-class versatility, next generation Renault Triber redefines the standards of the family vehicle. With an innovative fusion of assertive design, spacious and ultra-modular interior, it accommodates up to 7 seats. Equipped with 21 standard safety features, travel with peace of mind, knowing excellence ensures your serenity.



Whether city or countryside, its robust style is your reliable companion. Experience a distinctive everyday life.

5 to 7 seats

**removable
3rd row easy fix
seats**

**ultra-modular
with over
100 seating
combinations**

**625 L
boot space⁽¹⁾**

**20.32 cm
display link
touchscreen
with wireless
smartphone
replication⁽²⁾**

**21 standard
safety features**

(1) in 5-seater configuration, 3rd row removed. (2) in emotion version.

interactive menu

01. design

02. roominess

03. technology

04. safety features

05. customization

pdf for download

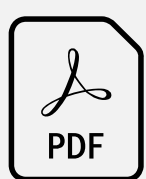

equipment and engines



accessories

style reimagined

A new generation with a compact and robust design, featuring more pronounced SUV styling than ever with its strong front face and silver finish skid plates⁽¹⁾. Drive in comfort with its elevated ground clearance of 182 mm and roof rails with load carrying capacity up to 50 kg. Add a touch of exclusivity with our new range of colours, including amber terracotta.



Renault Triber features the new emblem, a symbol of the brand's innovative spirit. Its expressive grille is wider and sculpted. A dynamic front bumper design enhances the car's presence with sharp lines and integrated air intakes.



Benefit from the sporty character provided by its 38.1 cm "landscape" dual tone styled flex wheels⁽²⁾ that emphasize its aerodynamic design.



It stands out with its meticulously crafted details that make all the difference. Head lamps, tail lamps and fog lights are equipped with LED technology for optimal brightness and a redesigned bumper for a striking appearance.



(1) from techno version. (2) in emotion version.

new generation interior

Experience a sense of clarity, space, and quietness within the cabin. An ergonomic and sleek dashboard, a 20.32 cm display link floating touchscreen⁽¹⁾ located within the driver's line of sight and steering wheel with all key controls at hand offer an enhanced driving experience.



Enjoy new harmonious light tones and expanded comfort with a thermally regulated atmosphere, thanks to the independent rear air-conditioning with 2nd and 3rd row vents⁽¹⁾.



(1) from evolution version.

[configure and order →](#)

5 to 7 seats

An unparalleled interior volume designed to be spacious. Each of the 7 seats offer maximum comfort with easy access to all rows and 200 mm of knee room in the second row, the best in its category. The generous 625 L trunk⁽¹⁾ is easy to load, making life on board even more practical.



The art of clever storage: 23 L of convenient compartments distributed throughout the cabin. Enjoy refrigerated center storage⁽²⁾ and lower glove box⁽³⁾ for journeys where nothing is left behind.



upper glove box & cooled lower glove box



center console cooled storage

(1) in 5-seater configuration, 3rd row removed. (2) from techno version. (3) in emotion version.

intelligent space

Experience record-breaking modularity that simplifies every moment of your everyday life: interior optimized to the centimeter for comfortable 7-person travel, with removable seats in the third row, 2nd row seats with slide/recline/fold and tumble function, and much more to offer a highly versatile interior.



Enjoy unparalleled flexibility with over 100 possible configurations.

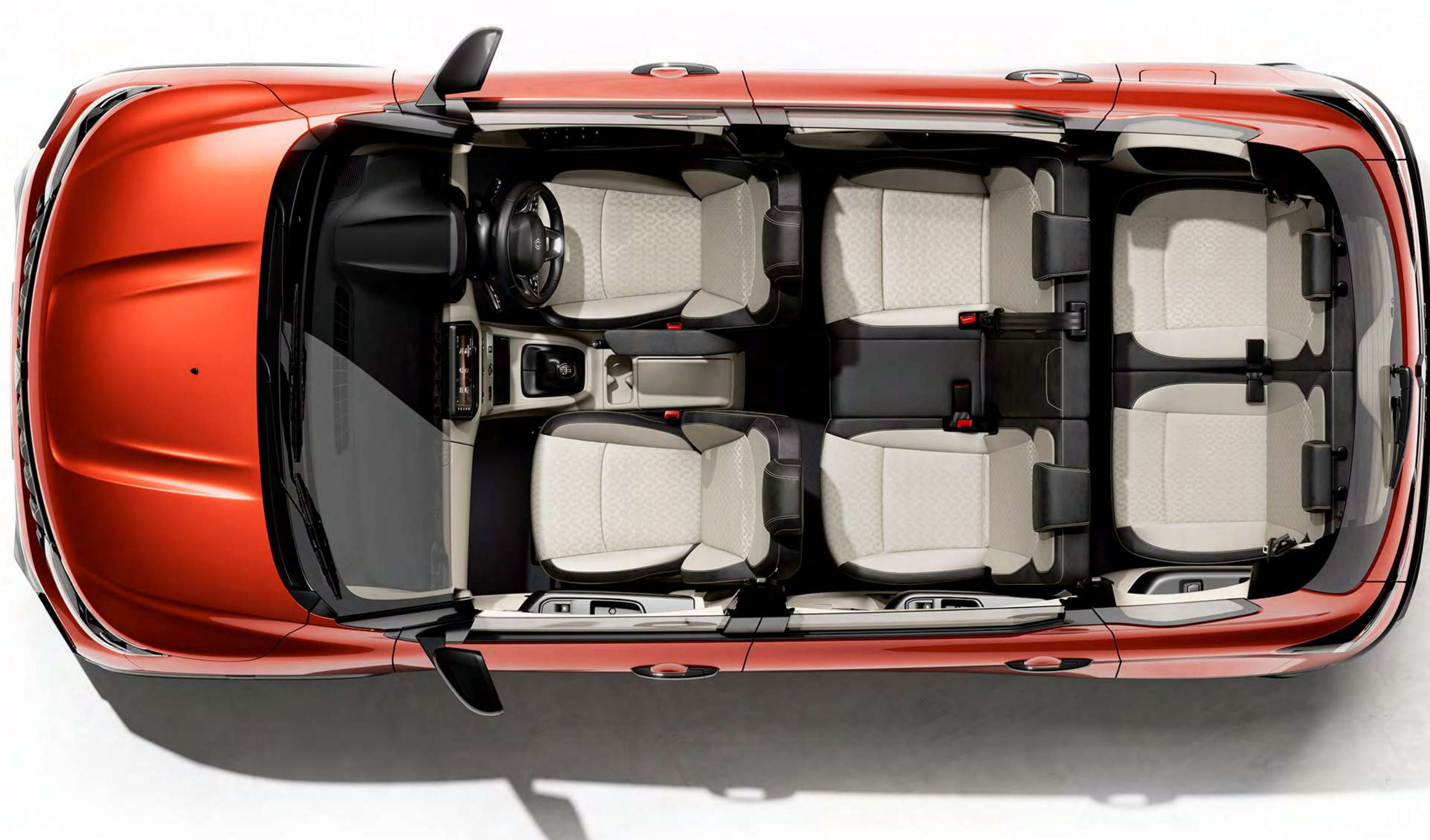

[configure and order →](#)

intuitive and efficient technology

The 20.32 cm display link floating touchscreen⁽¹⁾ is your essential travel companion, keeping you connected wherever you go. Enjoy your favorite apps like Google maps and more, with wireless smartphone replication⁽²⁾ on the central screen, thanks to Apple CarPlay® and Android Auto™.



The new 17.78 cm TFT instrument cluster⁽²⁾ behind the steering wheel allows you to view essential driving information.



Plug in and charge your devices, smartphone, music player, or laptop via the USB port on the console. While driving, securely place your smartphone on the wireless charging pad⁽²⁾ for quick and cable-free charging.



wireless charger



USB port

Android Auto™ is a trademark of Google Inc. Apple CarPlay® is a trademark of Apple Inc.

(1) from evolution version. (2) in emotion version.

[configure and order →](#)

04. safety features



21 standard safety features

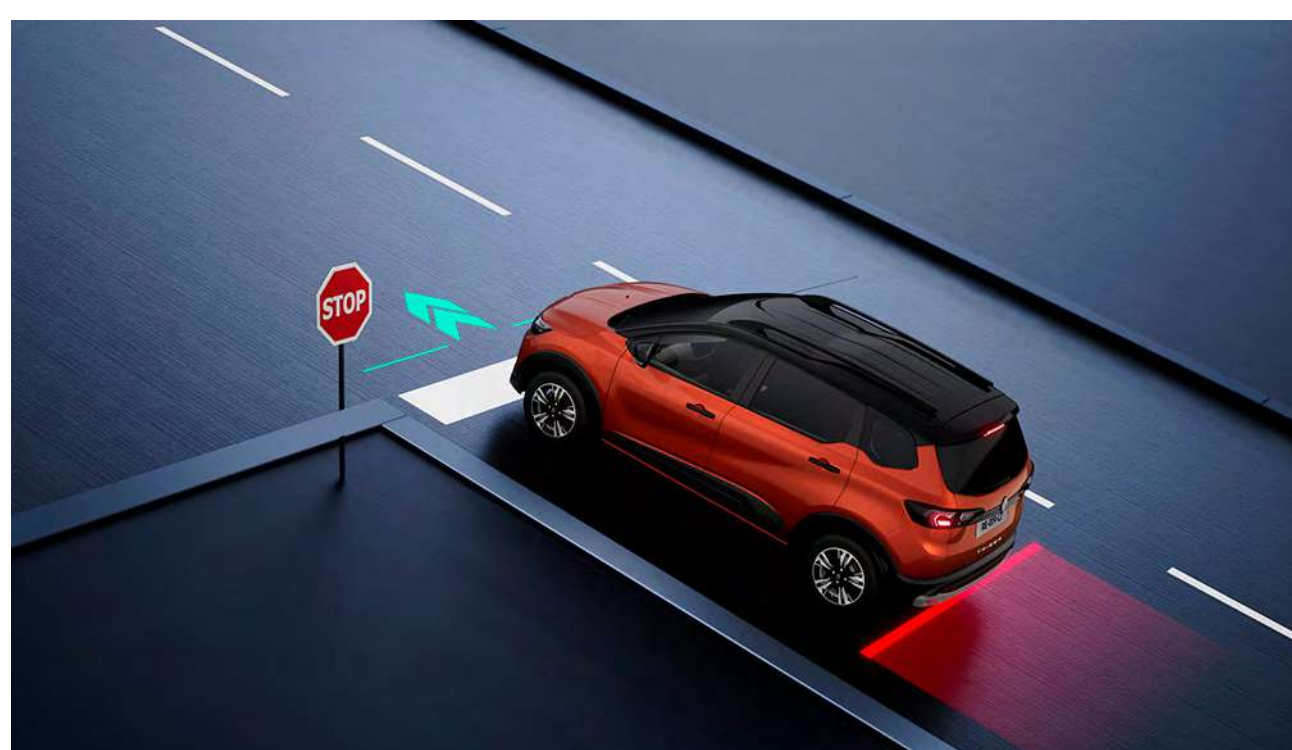

hill start assist
Maintains brake pressure for few seconds, preventing rollback when you move away on a steep slope.



electronic stability program
Automatically corrects your car's trajectory so you avoid dangerous skids.



traction control system
Limits wheel slip during starting, acceleration and braking.



front parking sensors
Ultrasonic sensors in the front bumper measure the distance between the vehicle and an obstacle.



tyre pressure monitoring system
Displays the tyre pressure status in real-time.



6 airbags
Six airbags offer increased protection.

driving assistance

- anti-lock braking system
- EBD with brake assist
- electronic stability program
- follow me home head lamps⁽¹⁾
- hill start assist
- speed alert warning
- traction control system

parking assistance

- front parking sensors⁽¹⁾
- rear parking sensors

security assistance

- curtain airbags
- front airbags - driver and passenger
- front seat belt with load limiter
- impact sensing lock-unlock
- Isofix with child seat anchorages
- seat belt reminder - driver + passenger
- seat belt with pretensioner (driver only)
- 2 side airbags (front seats)
- speed sensing door lock
- rear door child lock
- rear seat belt reminder
- pedestrian protection
- 3-point seat belt - all seats
- take-a-break reminder⁽¹⁾
- tyre pressure monitoring system

(1) in emotion version.

[configure and order →](#)

05. customization

colours



amber terracotta



shadow grey



zanskar blue



ice cool white



moonlight silver



stealth black

dual-tone colours



amber terracotta with mystery black roof



shadow grey with mystery black roof



ice cool white with mystery black roof

colour variants	authentic	evolution	techno	emotion	
	single tone	single tone	single tone	single tone	dual tone
amber terracotta	-	-	▪	▪	▪
shadow grey	-	▪	▪	▪	▪
zanskar blue	-	▪	▪	▪	-
ice cool white	▪	▪	▪	▪	▪
moonlight silver	▪	▪	▪	▪	-
stealth black	▪	▪	▪	▪	-

*photos not contractually binding

configure and order →

05. customization

authentic



- 2nd row seats – slide, recline, fold & tumble function
- removable 3rd row easyfix seats
- front & rear power windows
- 6 airbags



sporty all black woven upholstery



35.56 cm steel wheels
with "downtown" covers

05. customization

evolution



- 20.32 cm display link floating touchscreen
- rear-view camera
- 2 front & 2 rear speakers
- independent rear A/C with 2nd and 3rd row vents



sporty all black woven upholstery



35.56 cm steel wheels
with "downtown" covers

05. customization

techno



- LED signature tail lamps
- roof rails with load carrying capacity (50 kg)
- electrically adjustable ORVMS with LED turn indicators
- cooled centre console



suave black & greige woven upholstery



38.1 cm "landscape" black styled flex wheels

05. customization

emotion



- LED head lamps, DRLs, fog lamps & tail lamps
- auto headlamps and rain sensing wipers
- cruise control¹
- front parking sensors



suave black & greige woven upholstery



38.1 cm "landscape" dual-tone styled flex wheel covers



**download the pdf
versions and equipment**

(1) in manual transmission only.

configure and order →

05. customization

accessories



front grille insert

Add a bold touch to your vehicle's face with chrome front grille inserts. Designed to enhance the stance, this accessory adds a premium finish that's both elegant and assertive.



tail lamp surround

Elevate the rear look of your vehicle with chrome surrounds that frame the tail lamps with subtle contrast. A simple detail that adds definition and enhances the premium feel.



tailgate garnish

Complete the rear look with a chrome tailgate garnish⁽¹⁾ that lends a refined yet robust character. It integrates seamlessly with the design language of your vehicle while providing a stylish accent to the tailgate.



moulded mats

Keep your vehicle's floor looking clean and well-kept with mats that are shaped to match the cabin layout. Built for durability, they protect against everyday dust, spills and wear while offering easy maintenance.



seat storage bag

Designed to complement the modularity that Triber offers, the seat storage bag is a thoughtful add-on for everyday use. Designed to store the easy fix seats when removed.

⁽¹⁾ Available in Satin Chrome and Dark Chrome finishes.

 **download the pdf
of the accessories brochure**

configure and order →

05. customization

engines

authentic	evolution	techno	emotion
fuel			
multi point fuel injection			
fuel tank capacity (liters)			
40			
max power output (ps @ rpm)			
72 @ 6,250			
max torque (Nm @ rpm)			
96 @ 3,500			
gearbox			
5-speed MT	5-speed MT	5-speed MT	5-speed MT & Easy-R AMT



**download the PDF
engines**

dimensions

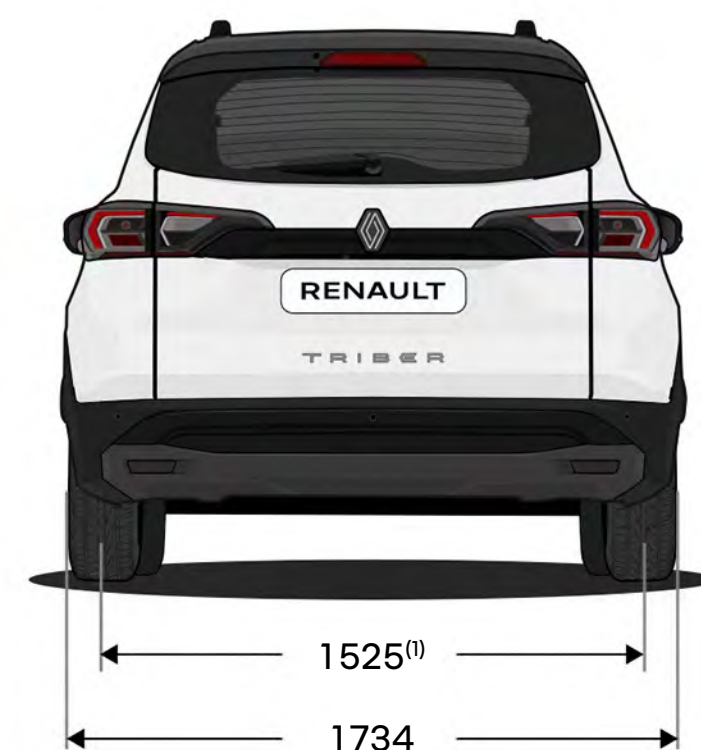
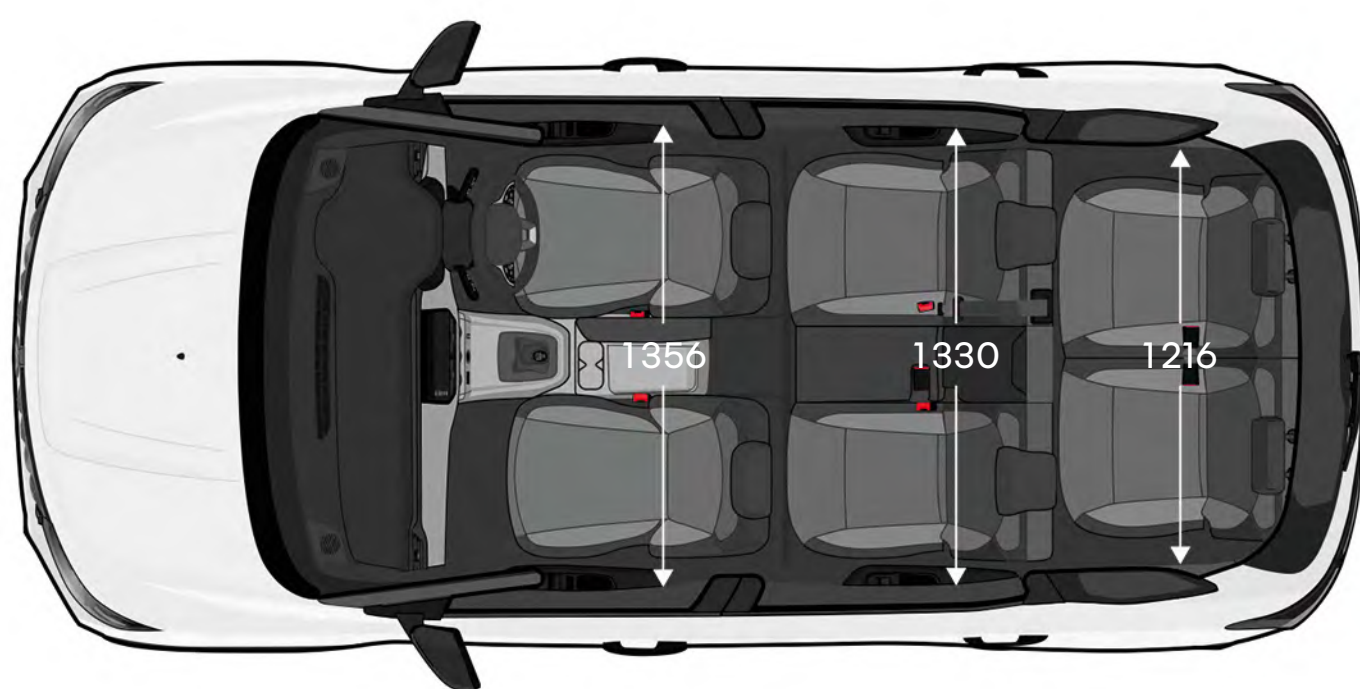
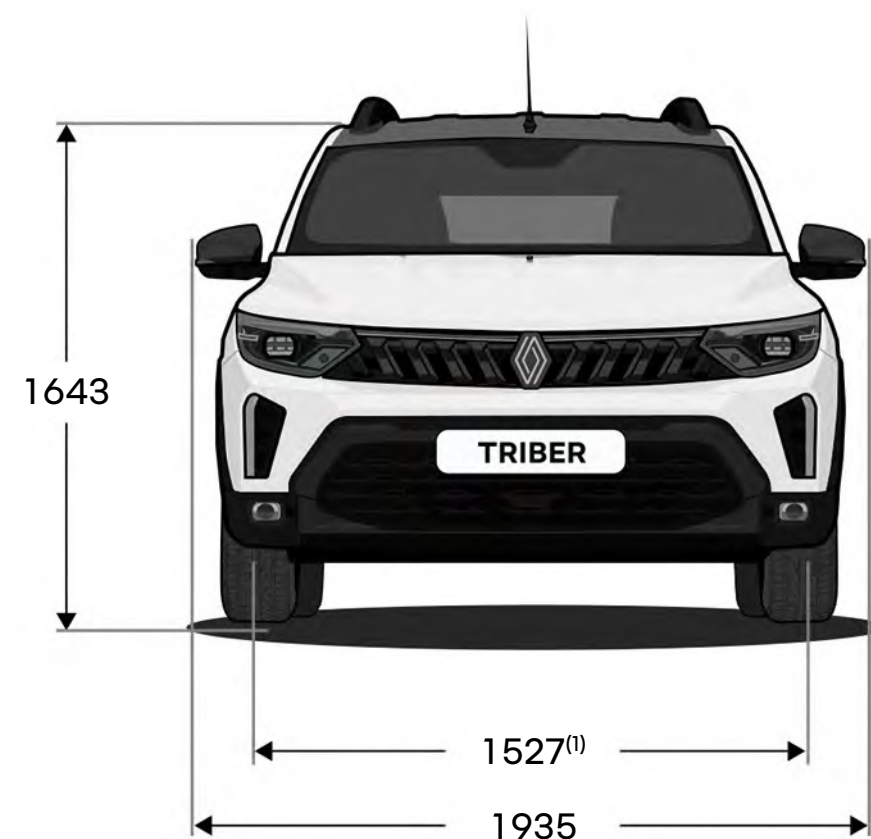
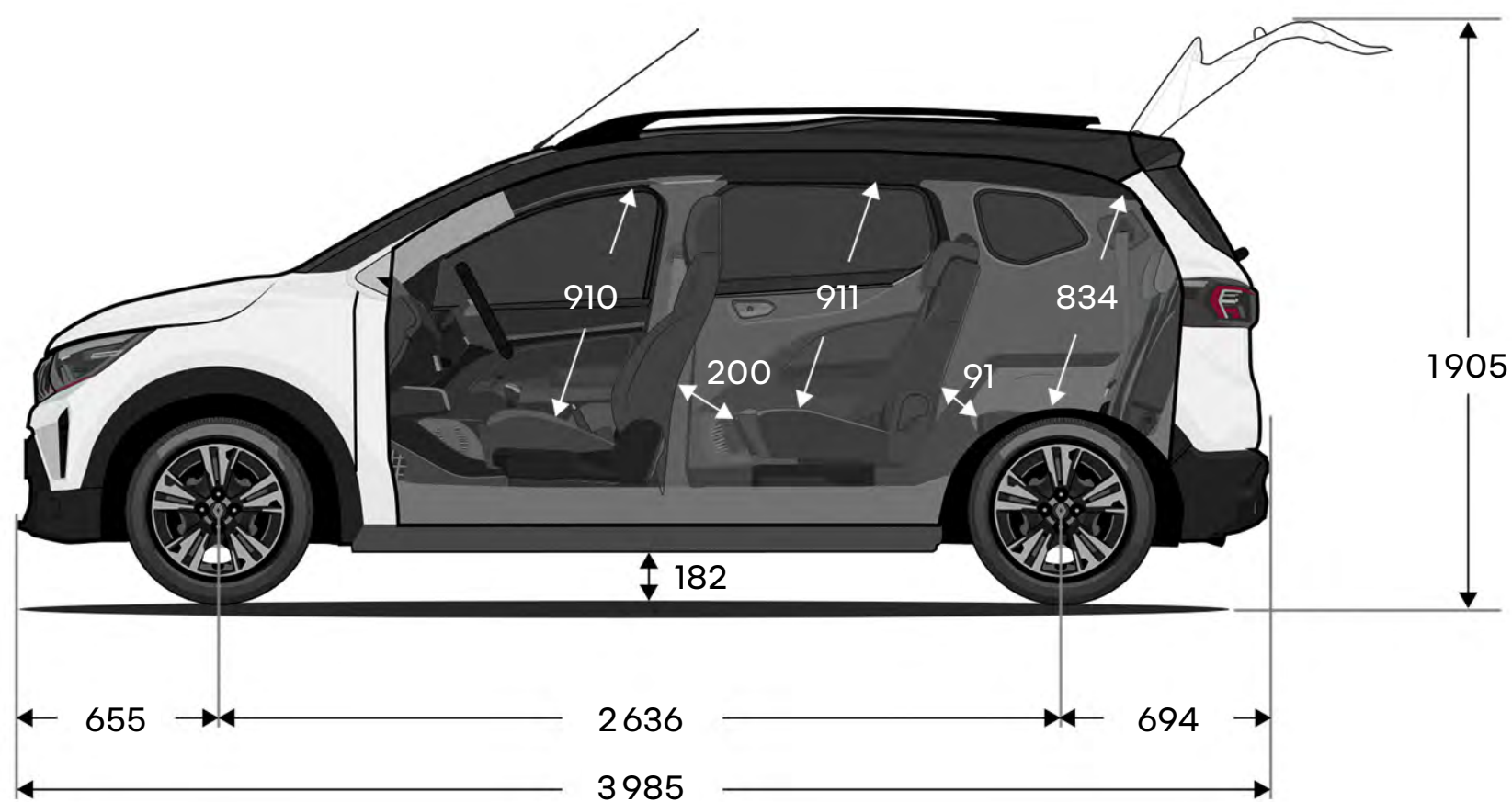

dimensions in mm
(1) techno and emotion variant

[configure and order →](#)

the human first program is a comprehensive safety program developed by Renault in collaboration with researchers, experts and fire-fighters.

because road safety is the business of all road users – be they pedestrians, cyclists or motorists – the human first program by Renault undertakes to:

- 1. prevent accidents by developing safety equipment and advanced driving and safety assistance systems**
up to 32 advanced driving assistance systems/more than 60 safety systems, up to 7 airbags, child seats (Isofix), Renault's Fixe4sure solution/more than 2,000 safety-related patents filed since 1970
- 2. manage accidents once they have happened by drawing on innovations developed in collaboration with fire-fighters**
QRescue/Fireman Access/more than 5,000 fire-fighters trained over the past 10 years in 20 countries throughout the world/around 400 cars given per year for their training
- 3. reduce the number of accidents and their severity by investing massively in R&D**
safety score/safety coach/connected services/big data/artificial intelligence and cybersecurity systems

[find out more about the human first program](#)

now with CNG

Upgrade your car with a government-approved CNG kit⁽¹⁾, available for retrofitment across manual transmission variants. Transition to a cost-efficient driving experience with Renault Triber CNG.

Enjoy complete peace of mind with a standard warranty of 3 years/100,000 km and no RC endorsement hassle. Unlock significant fuel savings along with the benefit of 7 seats.



(1) government-approved CNG kit fitment option is available within Renault network pan India. the CNG kit comes with a 3-year/100,000 km standard warranty (whichever occurs earlier).

Renault care service

We are always by your side to make your driving experience easier and save you time maintaining your Renault. We'll give you online estimates and appointments, service packages, maintenance contracts, insurance and assistance, the My Renault personalized program and more simple, easy solutions perfectly tailored to your needs.

[find out more about Renault care service](#)



every precaution was taken to ensure that this brochure was accurate and up-to-date when published. this document has been created using pre-production and prototype models. in line with its policy of continuous product improvement, Renault reserves the right to modify the specifications, vehicles and accessories described and featured at any time. any such modifications are communicated to Renault dealers as quickly as possible. depending on the country of sale, versions may differ and some equipment may be unavailable (standard, optional or accessory). please contact your local dealer for the latest information. for reasons to do with the medium, the colours featured in this document may differ slightly from those of the actual paintwork or interior trim. all rights reserved. reproduction in any format and by any means of all or part of this brochure is prohibited without prior written authorisation from Renault. Renault vehicles come with a standard warranty of 3 years or 100 000 kms, whichever is earlier. government approved cng retro fitment kit option is available with the renault network. the cng kit also comes with a 3-year standard warranty. our customer service team is available on our toll-free number from monday to sunday, between 7:00am to 11:00pm

publicis - photo credits: renault group - direction design - july 2025.
 renault s.a.s, a french simplified joint stock company with a share capital of € 533,941,113.00 / 122-122 bis avenue du général leclerc - 92100 boulogne-billancourt cedex, france - registered on the trade and companies registry (r.c.s.) of nanterre under number b 780 129 987 / tel.: 0806 00 20 20.

www.renault.com
 Call: 1800 315 4444

Renault recommends  **Castrol**



configure and order →